

AFRL'S DEMONSTRATION AND SCIENCE EXPERIMENTS (DSX) MISSION

Mark Scherbarth

Air Force Research Laboratory, Kirtland AFB, Albuquerque, NM

Durand Smith, Aaron Adler

ARES Corporation, Albuquerque, NM

Janet Stuart

ATA Aerospace, Albuquerque, NM

Greg Ginet

Massachusetts Institute of Technology, Lincoln Laboratory, Boston, MA

ABSTRACT

The Air Force Research Laboratory, Space Vehicles Directorate (AFRL/RV) has developed the Demonstration and Science Experiments (DSX) mission to research technologies needed to significantly advance Department of Defense (DoD) capabilities to operate spacecraft in the harsh radiation environment of Medium-Earth Orbits (MEO). The ability to operate effectively in the MEO environment significantly increases the DoD's capability to field space systems that provide persistent global space surveillance and reconnaissance, high-speed satellite-based communication, lower-cost GPS navigation, and protection from space weather and environmental effects on a responsive satellite platform. The three DSX physics-based research/experiment areas are:

1. Wave Particle Interaction Experiment (WPIx): Researching the physics of Very-Low-Frequency (VLF) electro-magnetic wave transmissions through the ionosphere and in the magnetosphere and characterizing the feasibility of natural and man-made VLF waves to reduce and precipitate space radiation;
2. Space Weather Experiment (SWx): Characterizing, mapping, and modeling the space radiation environment in MEO, an orbital regime attractive for future DoD, Civil, and Commercial missions; and
3. Space Environmental Effects Experiment (SFx): Researching and characterizing the MEO space weather effects on spacecraft electronics and materials.

Collectively, thirteen individual payloads are combined together from these three research areas and integrated onto a single platform (DSX) which provides a low-cost opportunity for AFRL due to their common requirements. All three experiments require a 3-axis stabilized spacecraft bus (but no propulsion), a suite of radiation sensors, and extended duration in a low inclination, elliptical, MEO orbit. DSX will be launch-ready in summer 2010 for a likely launch co-manifest with an operational DoD satellite on an Evolved Expendable Launch Vehicle (EELV).

Keywords: Wave Particle Interaction, electromagnetic wave transmissions, space radiation, characterization of MEO

1 MISSION OBJECTIVES

The top-level objectives for the DSX space flight experiment are to investigate the electromagnetic wave-particle (electron, proton, ion) interaction in the MEO region of space between the Van Allen radiation belts, also known as the 'slot' region; to collect space weather data in the slot region; and to collect data on the degradation of microelectronics, thermal, optical, and mechanical structures, surfaces, and coatings in the slot region. DSX is planned for an objective mission life of one year [1] due to the amount of data expected to be collected and required to meet program objectives, and due to normal operating procedures at the Space and Missile Systems Center

(SMC) Research, Development, Test, and Evaluation (RDT&E) Support Complex (RSC) at Kirtland Air Force Base (KAFB) for flying experimental satellite missions.

The overall primary objective of DSX is to resolve critical feasibility issues of injecting VLF electro-magnetic waves into the magnetosphere to determine how efficiently, how effectively, and to what degree of efficacy this can be accomplished. The goal is to assess the particle distribution, perturbations, and scattering effects on the particles as a result of the VLF waves produced by nature and by man-made systems on the ground and in space. In SWx, DSX shall measure and map the population distributions of energetic protons, electrons, and low energy plasma in order to better characterize the MEO region of space. In this way, DSX will assist in future spacecraft design by providing much improved models for spacecraft components in terms of radiation shielding and effects. Similarly, for the SFx, DSX will provide key data on the breakdown and degradation of optical, thermal, and mechanical materials, coatings, structures, and electronics.

DSX has one secondary experiment, ACE (Adaptive Controls Experiment). ACE software will perform automated on-orbit System IDentification (SysID) to produce Frequency Response Functions (FRFs) of the DSX spacecraft structures (i.e. Y and Z booms illustrated in Figure 1) and then demonstrate adaptive, on-orbit design of a Multi-Input, Multi-Output (MIMO) control law to meet performance objectives. ACE will operate at 80 Hz and will intimately interact with the spacecraft Attitude Determination and Control System (ADCS) which operates at 10 Hz.

DSX is slated to fly in a 6,000 km x 12,000 km elliptical orbit at 120 degrees retrograde. This orbit will permit DSX to fly through the outer region of the inner Van Allen radiation belt, the slot region, and the inner region of the outer Van Allen radiation belt. Launch date is October 2012.

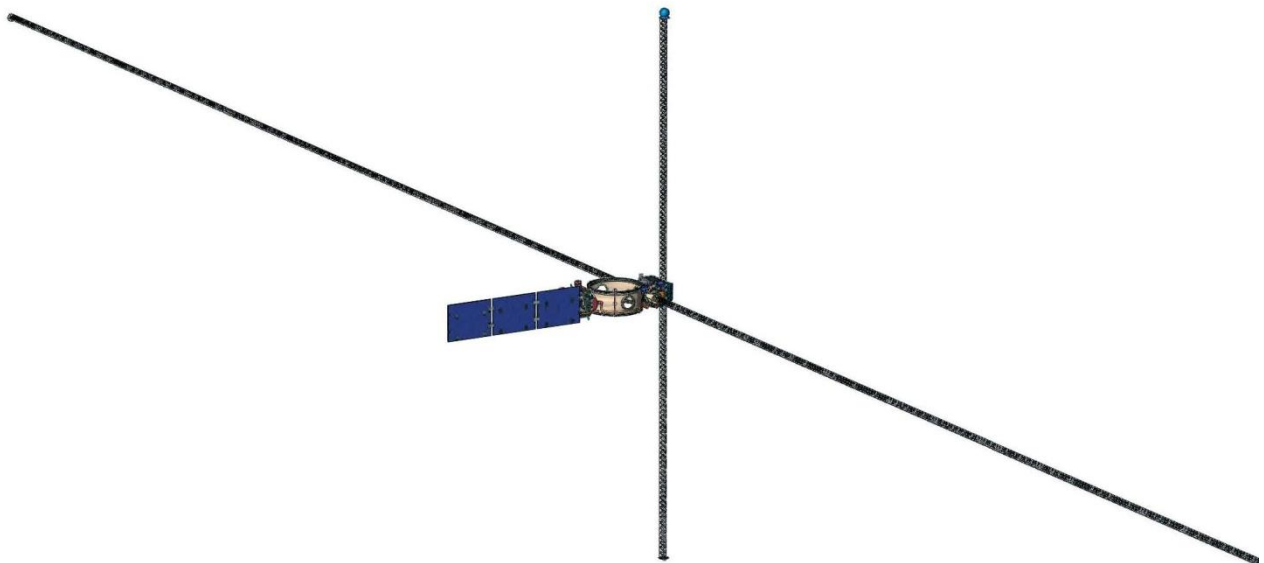

Fig. 1. DSX Deployed

1.1 Level 0, Level 1 Objectives

DSX has fifty-one level 0 and level 1[2] objectives guiding the mission objectives, spacecraft design, and CONcept of OPERations (CONOPS). The level 0 objectives are as follows:

1. The DSX system shall resolve critical feasibility issues for VLF Wave-Particle Interactions to include determination of VLF antenna injection efficiency from ground and space-based transmitters, characterization of the global distribution of natural and man-made VLF waves in the inner magnetosphere, and the detection of perturbations of particle populations due to injected VLF.

2. DSX shall measure and map the distributions of energetic protons, electrons, and low energy plasma in the inner magnetosphere to improve models for spacecraft design and operations.
3. DSX shall operate a minimum of one year in the space environment.
4. DSX will conduct an Adaptive Controls Experiment (ACE) to validate critical attitude control technologies that target flexible structural modes, adapt to changes in on-orbit dynamics and extend attitude control bandwidth.

2 PROGRAM-WIDE REQUIREMENTS

DSX has established a Common Requirements Document (CRD) [3] to convey/coordinate requirements common to most DSX payloads and subsystems, and the DSX system for environmental conditions, testing, and delivery. The CRD was authored by the DSX Program Management Office (PMO) team but references numerous DoD Handbooks, Military Standards/Specifications, and NASA documents. Requirements are split into General, Materials, Fabrication & Assembly, Grounding and Electrostatic Discharge, Electromagnetic Interference & Electromagnetic Compatibility, Acceptance, Qualification & Environmental Testing, Retesting and Nonconformance, Ground & Launch Environment, Operational Environment, Unit Level Testing Requirements, and Storage, Handling, and Delivery Requirements.

3 EXPERIMENTS

DSX has thirteen payloads arranged into three main groups of experiments: WPIx, SWx, and SFx

3.1 Wave Particle Interaction Experiment (WPIx)

The WPIx experiment consists of the following payloads:

Broadband Receiver (BBR), Transmitter and Tuning Units (TATUs), Transmitter Control Unit (TCU) including the Narrowband Receiver (NBR), Tri-Axial Search Coil (TASC), Vector Magnetometer (VMAG), Experiment Computer System (ECS), Loss Cone Imager (LCI), Y Antenna, and Z antenna.

- The BBR, TASC, Y antenna, and Z antenna make up the VLF broadband receiver (BBR). The VLF receiver has three search coil magnetometers (3 B [magnetic] components via TASC), two linear, orthogonal dipole antennas with 2 E (electric) components. The frequency range is 100 – 50 kHz and the sensitivity is $1.0e^{-16}$ V²/m²/Hz (E) and $1.0e^{-11}$ nT²/Hz (B). The VLF receiver is built by Stanford University, NASA/Goddard, Lockheed Martin, and ATK Space Systems Inc.
- The NBR and Y antenna constitute the VLF narrowband receiver covering the band from 3 kHz to 750 kHz. The VLF transmitter operates in two modes, high power (i.e. Whistler mode waves) at 3 – 50 kHz at up to 500 W (900 W at end of life), and low power mode (i.e. Boomerang mode waves) at 50 – 750 kHz at 1 W, the local electron density. The VLF transmitter is built by the University of Massachusetts Lowell (UML), Southwest Research Institute, and ATK Space Systems Inc.
- The LCI features a High Sensitivity Telescope (HST) which will measure 100 – 500 keV electrons with 0.1 cm²-str geometric factor with 6.5 degrees of loss cone. The LCI also features a Fixed Sensor Head (FSH) with 130 degrees x 10 degrees of pitch angle distribution for 50 – 700 keV electrons every 167 msec. Boston University is building the LCI instrument. Finally, the VMAG instrument is capable of 0 – 8 Hz three axis measurements at +/- 0.1 nT accuracy of magnetic field line measurements. The VMAG is built by the University of California Los Angeles (UCLA).

The WPIx experiment is designed to measure critical parameters for space and ground-based wave particle interactions: efficiency of VLF injection, propagation, and efficacy. The mission objectives for WPIx are to:

1. Determine VLF injection efficiency from a space-based antenna.
2. Map VLF fields from geophysical and man-made sources
3. Measure precipitating particles scattered by VLF from geophysical, ground-based transmitter, and DSX transmitter sources.

The design of the transmitter was driven by objectives 1 and 2, but also influenced by the desire to maximize space flight heritage to minimize risk, and budget constraints. The DSX Y antenna is 80 meters in length (tip-to-tip) and functions as a VLF receive and transmit antenna. The DSX Z antenna is 16 meters in length (tip-to-tip) and functions as a VLF receive antenna in a cross-dipole configuration with the Y antenna. The TASC and VMAG instruments are placed at opposite tips of the Z antenna to separate them from the rest of the DSX instruments and their electrical and mechanical “noise” which would interfere with their operation as VMAG measures the local magnetic field and TASC measures the local electric field.

The Y and Z antenna masts are both built by ATK Space Systems Inc. The Y antenna boom is a truss consisting of Graphite-Epoxy (Gr/Ep) longerons and batten elements with steel diagonals. In order to perform the VLF antenna function, copper wire is run the full length of each truss’s three longerons, attached at every other joint. The Z antenna boom is a similar truss with S-2 glass (fiberglass) material for the longerons and battens instead of the Gr/Ep. Both booms use frangibolt systems to constrain them within canisters through launch. Once on-orbit, the spacecraft powers the frangibolts in order to heat their Nickel-Titanium (NiTi) collars to the point that they break their bolts and release the tip plates from the canisters. The longerons are continuous elements that are “spring loaded” (with inherent strain energy) into the canisters via coiling. Thus, once released, the stored strain energy of each coiled system deploys the structures into their minimally strained, full length trusses. The deployment rate of each truss system is controlled by a lanyard with a geared friction damper, keeping the trusses from damaging themselves with excessive accelerations and/or sudden decelerations.

The antenna lengths were based on the generality among space physicists that the longer and wider the antenna the better due to minimizing impedance when generating VLF waves in a magnetized plasma. Estimates of scaling range from $L^{1/2}$ (plasma theory #1) to L^2 (plasma theory #2) bounded by L^4 (in vacuum), where “L” is the length of the antenna.

The transmitter voltage design is based on NASA’s Imager for Magnetopause-to-Aurora Global Exploration (IMAGE) Radio Plasma Imager (RPI) instrument built by UML that operated at 3 kV and was optimized for > 50 kHz. The DSX design optimizes the transmitter impedance dependant on frequency, antenna length, and diameter. DSX is flying the first ever VLF “dynamic tuning” technology to adjust circuit parameters in real time. The voltages are limited to < 10 kV due to critical component limits. The DSX system is nominally designed for 5 kV with the capability to go to 10 kV at the end of life (EOL).

3.2 Space Weather Experiment (SWx)

The objective of the Space Weather Experiments (SWx) are to measure, map, and characterize the space weather environment in the slot region for electrons, protons, ions, and plasma and then develop and validate models of this region. The SWx payloads are as follows:

- Compact Environmental Anomaly Sensor (CEASE)
- High Energy Proton Spectrometer (HEPS)
- Low Energy Imaging Proton Spectrometer (LIPS)
- Low Energy Electrostatic Analyzer (LEESA)
- High Energy Imaging Proton Spectrometer (HIPS).

CEASE will measure radiation dose, dose rate, surface dielectric charging, deep dielectric charging, and single event effects. HEPS will measure differential proton flux between 25 and 440 MeV. LIPS will measure protons and electrons with energies between 30 and 2,000 keV. LEESA will measure protons and electrons with energies

between 100 eV and 50 keV. HIPS will measure protons with energies between 30 and 300 MeV and electrons with energies between 1 and 10 MeV. DSX will be flying the most comprehensive particle energy coverage ever in MEO.

The benefits of the SWx experiment are that electron and proton detectors measure both the spectral content and angle-of-arrival of both species over broad energy ranges. Also, the DSX sensor suite will help correct deficiencies in the current standard radiation-belt models of the inner magnetosphere by providing:

- Spectrally resolved, uncontaminated measurements of high energy protons (10-400 MeV) and electrons (1-30 MeV).
- Accurate mid-to-low energy (< 1000 keV) measurements of the energetic particle and plasma environment.
- Transformation of angle-of-arrival measurements into estimates of the flux distribution with respect to the local pitch-angle (via on-board magnetometers).

3.3 Space Environmental Effects Experiments (SFx)

The Space Environmental Effects Experiments (SFx) consist of the NASA Space Environment Testbeds-1 (SET-1) and the Air Force Research Laboratory; Propulsion Directorate (AFRL/RZ) produced radiometers and photometers. The objectives of SET-1 are to improve engineering approaches to accommodate and/or mitigate the effect of solar variability on spacecraft design and operations, reduce risk for new technologies infused into future space missions, and provide a standard mechanical, electrical, and thermal interface for a collection of small flight investigations. The SET-1 payload consists of two units, the Correlative Environment Monitor (CEM) and the Central Carrier Assembly (CCA). The carrier provides a single interface for power and data between the DSX spacecraft and the SET-1 microelectronic investigations (inside the CCA) and CEM.

The CCA houses four sub-experiments:

- Dosimetry Inter-comparison and Miniaturization Experiment Board #1 (DIME-1)
- Dosimetry Inter-comparison and Miniaturization Experiment Board #2 (DIME-2)
- Linear Enhanced Low Dose Rate Sensitivity (ELDRS)
- Commercial Off the Shelf Technology – (COTS-2)

The SET-1 Project is part of the Living With a Star (LWS) Program managed at NASA Goddard Space Flight Center (GSFC). The LWS Program and SET -1 Project are sponsored by NASA Headquarters Science Mission Directorate.

The photometers and radiometers (Figure 2) will directly measure changes in optical transmission, thermal absorption and emission due to the MEO radiation environment. Coupon level testing of specific developmental coatings intended for thin-film photovoltaics will be performed using these sensors. The radiometers will detect changes in thermal control paint coefficients of heat gain / loss based on exposure and the photometers will measure the effects of erosion from quartz windows and re-deposition of material onto nearby optics.

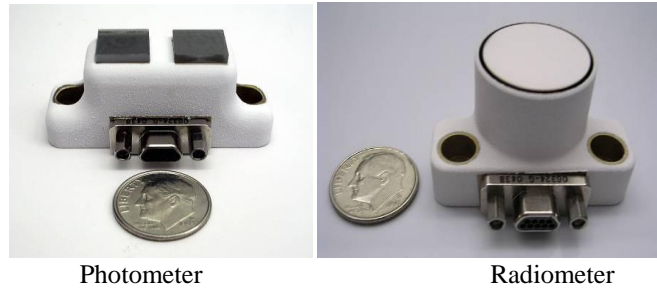

Fig. 2. Photometer and Radiometer

4 **HOST SPACECRAFT BUS (HSB)**

The HSB, provided by Sierra Nevada Corporation (SNC), consists of the Avionics Module (AM), the Payload Module (PM) structure and the harness attached to the EELV Secondary Payload Adapter (ESPA) ring connecting the two modules together electrically. The AM is essentially the spacecraft bus with all the requisite subsystems (communications, power, thermal, attitude determination and control (ADCS), command and data handling (C&DH), etc). It also houses the HEPS instrument, the Experimental Computer System (ECS), and the radiometers and photometers. The PM contains all the DSX specific components, except those just mentioned, along with the HSB Magnetometer and inertial measurement unit (IMU). The modules are mechanically bolted to the ESPA ring via a 15 inch bolt circle on two opposing ports of the DSX four port ESPA ring. The ESPA ring was first flown on the Space Test Program-1 (STP-1) mission in April 2007 and was designed and built by CSA Engineering. DSX will fly the ESPA ring with both AM and PM attached at all times; the AM and PM will not separate. The AM and PM are each mechanically connected to the ESPA ring via a conical adapter, part of SNC's module design, a SoftRide system developed by CSA Engineering for shock and vibration suppression and attenuation. The DSX in its stowed configuration is shown in Figure 3.

DSX has no propulsion, GPS unit, or star trackers. DSX does have an IMU, three sun sensors, and a magnetometer (in addition to the VMAG unit) for ADCS functions.

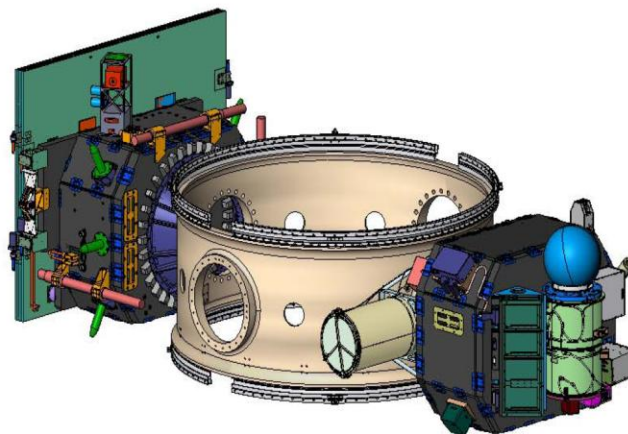

Fig. 3. DSX Stowed Configuration

The DSX Power subsystem consists of two Lithium Ion 30 amp-hr batteries designed and manufactured by Yardney, Inc., a fixed, single wing, three panel solar array (with composite facesheets and Al honeycomb core) with triple junction gallium arsenide (GaAs) cell technology, 28.5% efficiency beginning of life (BOL), and the associated switches, diodes, and wiring.

The DSX thermal subsystem consists of closed-loop heaters, white paint (AZ-93 or Alion Z-93) on the Y-boom canisters, and multi-layer insulation (MLI, 12 layers – 1 black Kapton, 10 Mylar, 1 AL Kapton). White coatings (Z-93C55) and black coatings (MH55-ICP) coat the structural surfaces of the AM and PM (black on the outside, white

on the inside with an emissivity > 0.8). The ESPA ring is an all aluminum structure that serves as a large heat sink for the DSX spacecraft. DSX also has 63 temperature sensors distributed around the spacecraft with 47 of them as AD590s and 16 of them as Platinum Resistance Thermometers (PRT). Predicted temperatures for DSX range from a max cold of -116 C for the Y and Z antennas to a max hot of 45 C for the CXS-810C L-3 Space Ground Link Subsystem (SGLS) radio. The duty cycle for the heaters is no greater than 72%.

The structures and mechanisms subsystem of DSX consists of the AM structure, the PM structure, the ESPA ring, solar array panels, and the associated bulkheads and brackets. The margins of safety inherent in the designs are 8.5 g's in two directions simultaneously which worst case is 12 g's in each of three directions individually. The ultimate factor of safety is 1.4. The ESPA ring was qualified for flight for the STP-1 Mission and the qualification test data correlated to FE (Finite Element) models. DSX's ESPA ring has a few modifications (4 port boss ports vs. the original 6 flange ports), so the DSX PMO had CSA engineering perform a Qualification by FE Analysis for the new design that showed positive margin with a safety factor of 2.0 for the same testing conditions as STP-1's qualification tests and the basic DSX design. The AM and PM flight structures were workmanship tested by subjecting them to sine burst levels up to 14.4 G's (1.2 safety factor) with mass simulators in place of payloads.

The DSX command, control, communications and data handling subsystem consists of the SGLS CXS-810C transmitter radio built by L-3 Communications Inc., the integrated avionics system (IAS) built by SEAKR Engineering Inc., the AM, PM, and ESPA harnesses built by Cicon Engineering Inc., the experimental computer system (ECS) built by Planning Systems Inc. (PSI), space-qualified RF switches, couplers, and diplexers, six helical antennas, and two omni patch antennas. The CXS-810C is a SGLS transponder radio with a BAE provided RAD750 processor providing SGLS uplink at 2 kbps and SGLS downlink up to 2 Mbps with ranging capability. Uplink and downlink signals will be encrypted. With an orbit of 6,000 km x 12,000 km, the uplink margin will be 23.2 dB worst case at 2 kbps and the worst case downlink margin will be 5.0 dB for safe mode at 500 bps and 5.1 dB in nominal operations at 1 Mbps. The worst case ranging margin will be 8.1 dB. The L-band command uplink operates at 2 kbps and can be received by either of the two Right Hand Circular Polarization (RHCP) patch antennas for approximately 4π steradian coverage. The six helical antennas are high data rate downlink only and are spaced around the AM structure and each has a 64 degree field of view (FOV).

The DSX ADCS consists of the VMAG, a Northrup Grumman-provided IMU running at 400 Hz, a Billingsley magnetometer (also known as the HSB Magnetometer), three Adcole sun sensors working together as the Sun Sensor Assembly (SSA), three Honeywell 25 N-m-s reaction wheels, and three Zarm 400 A-m² magnetic torque rods. The magnetometers, sun sensors, and IMU provide the sensor data to the system for attitude control and command generation. Advanced Solutions Inc. (ASI) designed the ADCS subsystem and wrote the ADCS software. The reaction wheels and torque rods are controlled by this software to orient the spacecraft as required per the CONOPS.

The DSX software is split into three main groups as illustrated in Figure 4: Flight Software (FSW), payload software (PSW), and ground software (GSW). There are approximately 100,000 SLOC (source lines of code) for each. The flight software was written by SNC and has heritage in the Tactical Satellite-2 (TacSat-2) mission. It is written in C and C++. All the PSW and drivers were developed and written by PSI. This software resides on the ECS, which also contains 7 GB for payload data and processor dynamic memory in SDRAM (synchronous dynamic random access memory). The stored state of health (SSOH) memory for DSX is 50MB. All the payloads interface directly with the ECS; the ECS offloads the IAS from all payload functions. Therefore, the IAS only handles spacecraft bus functions and State of Health (SOH) and communicates using Consultative Committee for Space Data Systems (CCSDS) protocol (via the CXS-810C transponder radio) with the DSX GSW—the Octant Common Ground System (CGS). DSX will continue to use Octant's CGS through spacecraft integration and test (I&T) and into spacecraft storage. After coming out of storage, DSX will perform regression testing, Factory Compatibility Testing (FCT), and Launch Based Compatibility Testing (LBCT) with a new Lockheed Martin-developed ground system, Multi-Mission Space Operations Center Ground System Architecture (MMSOC GSA) developed for SMC/Space Development and Test Wing (SDTW) at the RSC where DSX will be flown. MMSOC GSA is a TT&C system that provides the ability to fly and rapidly transition one-of-a-kind satellites and technology demonstrations, R&D missions, and Operationally Responsive Space missions to military operations. The goal of the FCTs and LBCT will be threefold. The first objective is to verify and validate the data flow between the spacecraft and the ground system. This means the data leaving the spacecraft makes it (without any errors) to the ground system and the data leaving the ground system makes it (again, without any errors) to the spacecraft. We are NOT testing the

content of the data with this test, just that the data at the destination is the same as the data at the source. Our second objective is to validate and verify the command and telemetry list (CTL). This is the test where we do indeed want to verify the content of the information, i.e. the commands going up to the spacecraft and the telemetry coming down from the spacecraft. The telemetry consists of all the mission data and SOH. Finally, since DSX will be monitored and flown via the Air Force Satellite Control Network (AFSCN), our third objective is to ensure AFSCN compatibility. We can divide AFSCN compatibility into two aspects: Radio Frequency (RF) compatibility and Inter-Range Operating Number (IRON) database compatibility. Both of these are strictly related to the communications hardware of the AFSCN and the spacecraft. All three of these tests are expected to be performed with the AFSCN's Transportable Space Test & Evaluation Resource (TSTR) van which is a mobile Automated Remote Tracking Station (ARTS) for the AFSCN for such purposes.

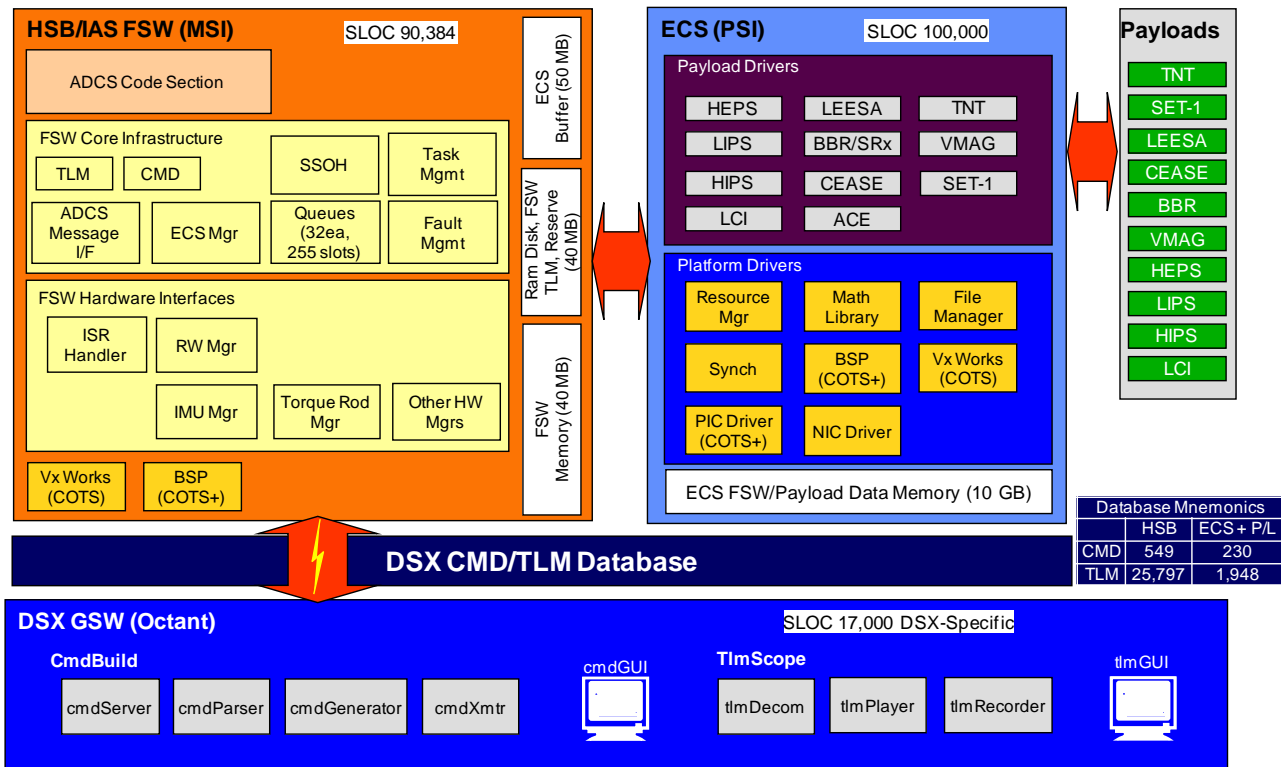

Fig. 4. DSX Software Configuration

One special feature of DSX is that it has two separation planes for launch. The first is to separate DSX from the primary (or upper) spacecraft. The second is to separate DSX from the Launch vehicle. DSX has a contract with Planetary Systems Corporation (PSC) to design, develop, build, qualify, and deliver the two 62.01 inch hole pattern diameter Latching LightBand (LLB) systems needed to perform these separation functions. The LLBs are fully mechanical (non-pyro) low shock separation devices. They use a series of rack-and-pinion latches and pins to tie two rings together. The latches are actuated via motor assemblies (multiple to stow and lock, a single assembly to release for spring loaded separation). These separation systems will be fully qualified per MIL-STD-1540E under the watchful eye of United Launch Alliance (ULA), Defense Meteorological Systems Group (DMSG), Launch and Range Systems Wing (SMC/LR), the Aerospace Corporation, SMC/SDTW, and the DSX PMO (Program Management Office) at AFRL/RV. During this development program, PSC will also build two straight LLB sections (9 inches and 16 inches), a 38 inch diameter LLB system, and a 62.01 inch diameter qualification unit before delivering the two 62.01 inch diameter flight units to the DSX program.

5 DSX CURRENT STATUS AND WAY FORWARD

DSX is currently in the Assembly, Integration & Test (AI&T) phase of the program which commenced in June 2009 and is expected to complete in fall 2010. SNC delivered the AM (integrated and functionally tested), the PM panels,

the solar array, and the ESPA and PM harnesses to AFRL. AFRL will integrate the PM structure, the PM harness, and all of the payloads. The AM and PM will then both go through shock and vibration testing to protoflight levels before being integrated together onto the ESPA ring (with the ESPA Harness) for EMI/EMC and thermal vacuum (TVAC) testing as an entire spacecraft. AFRL practices a test like you fly (TLYF) I&T philosophy and will use the Octant GSW throughout AI&T to thoroughly wring out the system with full confidence before storage.

DSX has been manifested for launch with DMSP (Defense Meteorological Satellite Program) Flight-19 (DMSP F-19) which is scheduled for an October 2012 launch on an Atlas V 401 launch vehicle from Vandenberg Air Force Base (VAFB). SMC/SDTW-STP is the lead agency for integrating DSX with DMSP F-19 onto the Atlas V.

6 ON ORBIT OPERATIONS (CONOPS)

6.1 Launch and Early Operations (L&EO)

After launch DSX enters the L&EO phase of the mission. During this period DSX separates from the launch vehicle and begins a sequence that will deploy the solar array and lead to safe mode for the SV (Space Vehicle). The same safe mode is used throughout the mission. At the first available AFSCN (Air Force Satellite Control Network) pass, commands will be uplinked to turn the SGLS transmitter on and transmit SOH data. The telemetry downlinked will indicate if the spacecraft has acquired the sun and is power and momentum positive. Based on telemetry, the SV will be commanded out of safe mode when it is determined it is safe to do so.

Once it is determined that the DSX SV is ready for operations, the antenna deployments campaign will begin. Each deployment will be scheduled to occur during a single contact. In addition to the deployments, data will be collected to determine the magnetic signature of the SV. This will be accomplished by commissioning VMAG and the ECS prior to any deployments. Once VMAG is in operation, a baseline magnetic measurement will be conducted. After confirming that the Z-antenna canisters are in the correct temperature range, the ADCS will be placed into Idle Mode and the two commands required for the Z-antenna deployment will be sent. VMAG will monitor the change in spacecraft magnetic field during deployment. Following the deployment, the ADCS will again be commanded into Sun Track mode. Once the SV is stabilized and ready for operation, another magnetic baseline measurement will be made and the deployment sequence will be repeated for the Y-antenna. Once the antenna deployments are complete, a contact will be scheduled to perform a SysID as a part of the ACE experiment.

Following the antenna deployments and the SysID characterization, payload commissioning will begin. The guiding philosophy for the commissioning sequence is to obtain an on-orbit VLF signature for each payload, group payloads by provider, and turn on the high voltage instruments last, after a hard vacuum can be assured. The VLF receivers (BBR and NBR) will be commissioned to measure the VLF signature. In addition, the TASC (which is controlled by the BBR) will be commissioned with the BBR. With the VLF receivers on, the remainder of the payloads can be commissioned.

HIPS and LIPS are commissioned next and are followed by HEPS and CEASE. NASA's SET-1 is next, followed by LCI. The radiometers and photometers are simple devices that are monitored through the IAS directly. Commissioning involves verifying that the sensors are reading expected values.

LEESA is the first high voltage instrument to be commissioned. LEESA will be followed by the two VLF Transmitter and Tuner Amplifier Units (TATUs). Once the TATUs are commissioned they will be used with the Transmitter Control Unit (TCU) to characterize the Y-antenna in the space plasma environment.

6.2 Normal Operations

Once L&EO is complete, normal operations will commence for 12 months. The RSC is responsible for commanding and monitoring the state of health (SOH) of the spacecraft, monitoring the SOH of the payloads, downloading the payload and SOH data, and distributing the data to the DSX Payload Operation Center (POC). The DSX POC will perform all payload planning, archive the payload and SOH data, and perform secondary distribution.

The SWx and SFx payloads will be collecting data immediately after commissioning and, barring any anomalies, are planned to remain on for the mission duration. The WPIx payloads will be controlled by commands uploaded to the spacecraft which will be provided as required by AFSCN scheduling, space weather and other unpredictable events. As stated previously there are three experimental objectives for WPIx:

1. Quantify in-situ ELF/VLF wave excitation
2. Quantify magnetospheric ELF/VLF environment
3. Quantify ELF/VLF wave-induced precipitation

There are 14 unique experiments that will be executed to achieve these objectives. These 14 experiments can be categorized as either transmit, receive or particle precipitation. The WPIx payloads are commanded jointly for each experiment. The WPIx science team will collaborate on a regular basis to determine experiment scheduling and corresponding payload commands and to conduct focused experimental campaigns. These campaigns will be conducted to satisfy and (hopefully) exceed the minimum mission requirements.

Conjunction opportunities with other spacecraft are planned during the DSX mission. Possible spacecraft include the Canadian Space Agency's (CSA) CASCade Smallsat and IONospheric Polar Explorer/enhanced Polar Outflow Probe (CASSIOPE/ePOP), NASA's Radiation belt Storm Probe (RBSP), CSA and NASA's Outer Radiation Belt Injection, Transport, Acceleration and Loss Satellite (ORBITALS), and France's (CNES) Tool for the Analysis of Radiation from LightNing and Sprites (TARANIS).

DSX will perform WPIx campaigns in cooperation with several ground sites. Potential work may exist with the following ground sites: the High Frequency Active Auroral Research Program (HAARP) site in Gakona, AK operating with ELF-VLF at 3.6MW, the VLF ground site in Exmouth, Australia (call sign NWC) operating at 19.8 kHz and 1MW, the Lualualei, Hawaii VLF transmitter (call sign NPM) operating at 21.4 and 23.4 kHz and 0.566MW, and the Cutler, Maine VLF transmitter (call sign NAA) operating at 24.0 kHz and 0.750/1MW.

DSX also plans experiments with lightning. The objective is to determine the climatology of lightning stroke rate as a function of location and season for optimal planning of the WPIx. Another goal is to quantify the VLF emissions from lightning and the resultant energetic electron scattering in the magnetosphere. The best chances for coordinating lightning experiments appear to be above Florida and South America. The Lightning Imaging Sensor (LIS) on NASA's Tropical Rain Measuring Mission (TRMM) satellite and the Optical Transient Detector (OTD) on Orbital Science's Microlab-1 satellite can provide monthly lightning climatology at 0.5 degree resolution that would provide a good estimate of lightning occurrence for DSX lightning-related simulations for mission planning.

Other measurement campaigns, such as the antenna characterization, will be scheduled and a two week high-power VLF transmission campaign will occur near the end of the mission. ACE campaigns will occur as opportunities present themselves, but a minimum of two other times during the mission, at approximately 6 and 11 months.

Per the mission agreement, upon completing one year of operations DSX will terminate operations and implement the end of life plan (EOLP) to safe the vehicle. Since DSX is already in a "graveyard" orbit, there will be no need to maneuver to a disposal orbit. The EOLP involves passivating the spacecraft by dumping the momentum stored in the wheels, disconnecting the solar arrays to prevent recharging the batteries, discharging the batteries as completely as possible, and turning off the transponder.

REFERENCES

- [1] Ginet, G., P., "Minimum Mission Duration for DSX Success", DSX Internal Memo, 4 June 2007
- [2] DSX Level 0 and Level 1 Requirements Document, DSXL0L1, Rev D, 13 April 2009
- [3] DSX Common Requirements Document, DSXCRD, Rev G, 15 July 2008